

INSTRUCTION MANUAL
TO
CONVERSION KIT
FOR
CZ 75 D COMPACT CAL. 9 MM FX & CQT

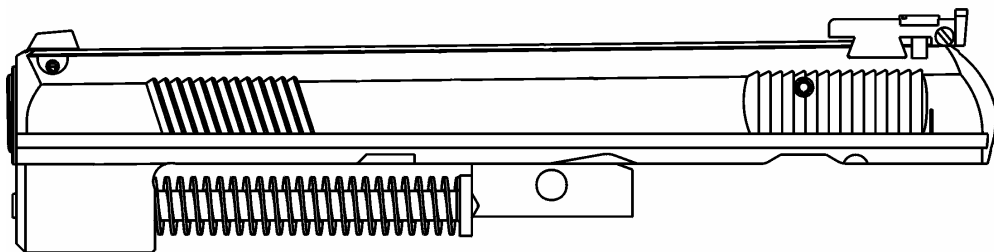

ČESKÁ ZBROJOVKA

Before handling the CZ 75 D Compact Conversion Kit CAL. 9 MM FX & CQT, designed for the CZ 75 D Compact pistol, read these operating instructions and Instruction Manual supplied with the CZ 75 D Compact CAL. 9 MM pistol. Follow the Safety Instructions presented for the CZ 75 D Compact CAL. 9 MM pistol Instruction Manual also while operating this conversion kit.

Improper and careless handling with this conversion kit could result in unintentional discharge and could cause injury or damage to property. The same consequences can be caused by unauthorised modifications or adjustments, corrosion or use of non-standard or damaged ammunition. In these cases the manufacturer shall not be responsible in any manner whatsoever for the resultant consequences.

Before these conversion kits prototypes were provided to SIMUNITION Division SNC Technologies Inc., they were tested, carefully inspected, and packed. CZ cannot accept responsibility for conversion kits handling upon leaving the factory.

This instruction manual should always accompany this conversion kit and that even in the case of the loan, be sure this instruction manual goes with it.

CONVERSION KIT DESCRIPTION AND TERMINOLOGY

The names of all parts used in this Instruction Manual are illustrated on page 8. Nomenclature of all other pistol parts is identical with the names used in the Instruction Manual for the CZ 75 D Compact CAL. 9 MM pistol.

The CZ 75 D Compact CAL. 9 MM FX & CQT conversion kit consists of blowback breech with the barrel adapted for SIMUNITION 9 MM FX & CQT cartridges. The barrel is in the slide/conversion kit held by the recoil spring and recoil spring guide. The extractor and extractor spring are mounted on the right hand side. At the front of the conversion kit the barrel bushing is pressed in and above it is the front sight held in its position by a roll pin. The firing pin is sited in the rear part secured in its position by a roll pin. The rear sight is implanted on the top rear part of the slide/conversion kit.

The conversion kit is designed for instalment in the frame assembly of the CZ 75 D Compact CAL. 9 MM pistol and training with SIMUNITION 9 MM FX & CQT type of cartridges.

Characteristic features are as follows:

- besides „blue-training colour” it is in its design and styling identical with the „real” slide of the CZ 75 D Compact CAL 9 MM pistol, so it simulates the feeling of shooting as if the „real” pistol was used
- the barrel is provided with two „live fire exclusion” slots which prevent generating of pressure and consequent propelling of „real” standard or lethal projectile from a converted weapon
- no need for any special magazine, the CZ 75 pistol standard magazine is used
- takes over properties found and manifested at the CZ 75 D Compact in these aspects:
 - comfortable grip and balance in either hand
 - low trigger pull weight
 - selective SA/DA firing mechanism operation
- the slide stays open after the last cartridge has been fired
- the rear sight adjustable for elevation and windage

OPERATING INSTRUCTIONS

Ammunition

Use only 9 MM FX & CQT ammunition made by SIMUNITION. The use of other cartridges could impair proper function, damage the handgun or cause injury to the shooter.

WARNING: Never use „life” lethal cartridge made and designed for the „real” firearm when shooting the conversion kit!

Conversion kit assembly and mounting

The conversion kit is supplied in assembled state. Actual disassembly procedure is analogue to disassembly of the CZ 75 slide - take the recoil spring and its plastic guide rod out and finally the barrel. Assembly is carried out in reverse order.

CAUTION: Never interchange the parts of the pistol with parts of the conversion kit!

Follow these instructions when mounting the conversion kit on the frame of the „real” CZ 75 D Compact pistol:

POINT YOUR PISTOL IN A SAFE DIRECTION!

1. Remove the magazine. The pistol must not be disassembled with the magazine inserted!
2. **MAKE SURE THAT THERE IS NO CARTRIDGE IN THE CHAMBER!**
3. Retract the hammer slightly back and then release it, until it stops on half-cock (safety) notch position. In this state the handling which follows will be easier.

4. Put your left thumb through the trigger guard and with the other fingers grasp the top of the front part of the slide firmly. Push the slide slightly back until the two vertical lines on the rear part of the frame and slide are in line with each other.
5. Keeping the lines aligned push (tap) the slide stop from the right hand side of the weapon, i.e. using the magazine base. Remove the slide stop from the left.
6. Pull the slide and the barrel forward off the frame.
7. Slid the conversion kit in to the pistol frame.
8. Push the conversion kit slightly back so as to set the hole by which the barrel sits on the slide stop to align it with the hole on the left side of the frame. Put the slide stop into this hole. Draw the slide further to the rear in such a way as to align the line on the pistol frame with the line located at the rear part of the conversion kit. Complete proper seating of slide stop.
9. Release the hammer to its forward (released-decocked) position.
10. Insert magazine into frame. The pistol is now rendered into its basic condition.

The same procedure applies for the conversion kit dismounting and installment of the „real“ slide. The same procedure is performed for the routine maintenance disassembly.

Magazine Loading and Removal

Standard procedure as for the „real“ CZ 75 D Compact. But there is a necessity to handle these cartridges with more care in order not to enucleate the bullet/projectile from the plastic sabot. We recommend that when some cartridges are already loaded in the magazine, depress them slightly with the thumb of the hand which holds the magazine.

The number of cartridges can be checked through the inspection holes in the sides of the magazine. Do not try to exceed the magazine capacity - doing so can cause a feeding failure.

Pistol Loading with Conversion Kit Installed

ALWAYS MAKE SURE THAT THIS TRAINING PISTOL WITH CONVERSION KIT INSTALLED IS POINTED IN A SAFE DIRECTION AS ANY OTHER FIREARM SHOULD BE!

Insert a loaded magazine and ensure that it has engaged the magazine catch. Hold the pistol by the grip with one hand, and with the thumb and index finger grasp the serrated finger grips on both sides of the slide/conversion kit. Retract the slide to the stop and allow it to snap forward. This procedure cocks the hammer and inserts a cartridge into the chamber. The training pistol is now ready to fire. If you do not intend to shoot immediately lower the hammer from the cocked position to the hammer safety notch position using the decocking control

lever applying the same procedure as for the „real“ CZ 75 D Compact. In this state the pistol is safe for all normal handling and at the same time ready for immediate use. Please remember that the safest way to secure a pistol is to unload it and store it in a safe place!

Reloading During Shooting

When the last cartridge has been fired the slide will stay to the rear. Remove the emptied magazine and replace it with a loaded one. Thumb down the slide stop with the shooting hand, or with the other hand draw back the slide and allow it to snap forward. The pistol is again loaded and ready to fire.

Unloading the Pistol

ALWAYS MAKE SURE THE PISTOL IS POINTED IN A SAFE DIRECTION!

- Remove the magazine
- Draw back the slide and verify the last cartridge has been extracted from the chamber and ejected
- Let the slide snap fully forward
- Depress the trigger (dry fire)

Sight Adjustment

Since the conversion kit is a blowback breech - the barrel is not locked - the accuracy of fire is also affected by the positioning of the barrel in the frame. For this reason, it is necessary, after instalment of the conversion kit in the particular frame to adjust the sights both for elevation and windage. For this purpose the conversion kits are equipped with adjustable rear sight with setting screws for elevation and windage adjustments.

However, it is necessary to adjust the sights for elevation each time when changing cartridges from FX type to CQT and vice versa which is given by the respective bullet characteristics. When shooting CQT cartridges the rear sight should be at the lower position, when shooting FX cartridges at the upper position in order that the mean point of impact for both types of bullets to be at the same level. In case of need there is an option to exchange also the front sight, which is secured by a roll pin. This procedure should be entrusted to a competent gunsmith.

MAINTENANCE INSTRUCTIONS

Cleaning the Barrel Bore and the Cartridge Chamber

If the pistol has not been fired or if only a few cartridges have been fired, clean the barrel bore and cartridge chamber by the clean patch attached to the cleaning rod. Clean the barrel bore preventively after approx. 100 fired rounds when shooting

CQT cartridges as the fouling of grooves resulting from plastic bullets abrasion is more clearly manifested. When the barrel bore is very dirty, apply a gun cleaning solution using a cleaning brush. Let the solvent act for about 10 minutes (this time may vary depending on the solvent agent being used). Then thoroughly scrub out the barrel bore. Subsequently, dry the barrel bore and cartridge chamber with a clean patch and check that all powder residues or fouling and bullet barbs have been removed. If necessary repeat this procedure.

The cleaning rod and the brush must be inserted into the barrel bore from the chamber, to prevent wear or damage to the muzzle. Pass the brush all the way through the barrel bore before reversing the movement. If you try to change directions with the brush in the barrel, the brush could stick.

Cleaning of Other Pistol Parts

Other parts of the pistol (including the external surfaces of the barrel) should be cleaned with a dry cloth, old toothbrush, brass bristle brush or a wooden scraper. Preserving oil or paraffin oil can be used for proper cleaning. Never use the agent designed for barrel bore cleaning! These solutions could remain in the joints, and after some time could cause corrosion. Check that cloth particles or brush bristles have not become lodged in any part of the pistol.

Preserving

When the barrel bore, cartridge chamber, and all accessible parts are clean and dry, wipe these parts with a cloth soaked in gun oil or apply the oil in a spray. Remove all excess oil.

Before shooting always wipe the barrel bore dry. At very low temperatures remove the oil from all accessible parts or apply a lubricant prepared especially for these conditions.

Use thick preserving agents for example, preserving grease only for a long-term storage in demanding climate environments, and before any use of the pistol it must be thoroughly removed from all parts of the firearm.

TROUBLESHOOTING, CAUSES AND REMEDIES

If your pistol is properly used and maintained, malfunctions will rarely occur. However, if such a situation does occur, please observe the following instructions.

CAUTION: If a malfunction occurs, the possibility of unintentional discharge is substantially increased. For this reason, carefully observe the Safety Instructions already mentioned above. Keep the pistol pointed in a safe direction, do not turn the pistol against your body or anyone else's! Do not place your hands in front of the barrel!

Malfunction	Possible Cause	Remedy
A round has not been fed into the chamber or the slide has not fully locked with the barrel.	Magazine is not fully inserted or is damaged. The pistol or cartridges are fouled (dirty) or too heavily greased.	Insert magazine properly or change magazine. Clean the pistol and cartridges and wipe them dry or as case may be slightly lubricate.
Misfire	Defective cartridge Firing pin hole fouled (dirty) or improper lubrication agent used under low temperature conditions.	Pull the trigger again. If a discharge is not initiated, follow the Safety Instructions according to point 19. Disassemble and clean the firing pin or use a low temperature lubricant.
A shot sounds „weak” combined with failure to eject the cartridge case.	The primer has been activated but no powder load was inside the cartridge case.	Unload the pistol and check that the bullet is not lodged in the barrel. A subsequent shot could cause damage to the barrel.
The spent case has not been ejected.	Cartridge chamber, extractor or ammunition dirty, or unsuitable lubricant in low temperature environment.	Clean and wipe the pistol dry or lubricate lightly with a suitable agent. Use new and clean ammunition.

If you cannot clear away any malfunction in the manner described above, entrust the pistol to a competent gunsmith for inspection and repair.

TECHNICAL SPECIFICATIONS

Conversion kit caliber		9mm FX & CQT
Overall length with conversion kit	[mm]	184
Overall height with conversion kit	[mm]	137
Width with conversion kit	[mm]	37
Weight with empty magazine	[g]	max. 790
Length of conversion kit barrel	[mm]	104
Conversion kit sight radius	[mm]	135
Magazine capacity	[cartridges]	14
Number of grooves at kit barrel bore		6
Twist of kit barrel bore rifling	[mm/r]	254

ILLUSTRATION AND LIST OF PARTS

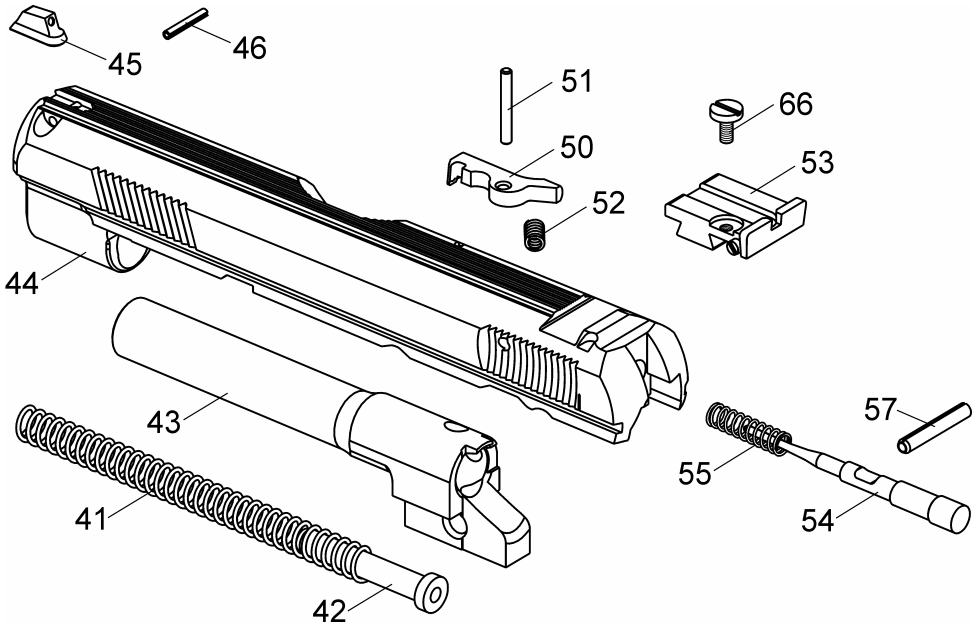

- | | | | |
|----|---------------------|----|---------------------|
| 41 | Recoil Spring | 51 | Extractor Pin |
| 42 | Recoil Spring Guide | 52 | Extractor Spring |
| 43 | Barrel | 53 | LPA Rear Sight |
| 44 | Slide | 54 | Firing Pin |
| 45 | Front Sight | 55 | Firing Pin Spring |
| 46 | Front Sight Pin | 57 | Firing Pin Roll Pin |
| 50 | Extractor | 66 | Rear Sight Screw |

The Company, reserves the right to make any changes it thinks necessary to improve its models or to meet any requirements of manufacturing or commercial nature.